

ZEBRATTI

Sliding Door Lock Installation Instructions

Aluminium 33mm Backset

LCS

Please note: Dimensions for lock and handles have all clearance added and all dimensions are set to fit lock easily.

3. File Bottom inside edge of handle cut out to remove extrusion fins.

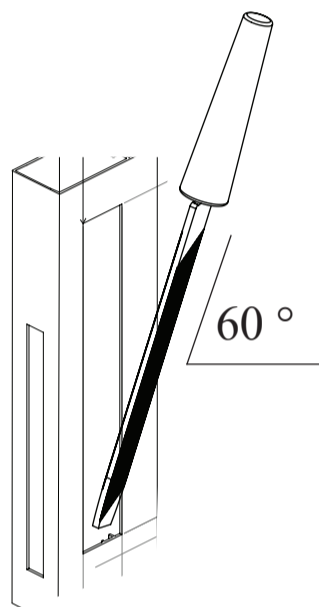

6. Tighten grub screw to lock handle into place.

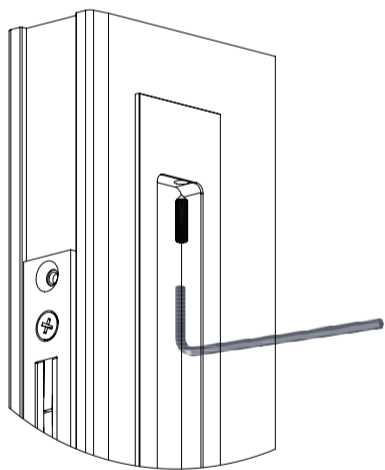

9. Align and Centre strike plate opposite the lock latch to suit engagement, measure the position of the strike plate from bottom of jamb. Mark and Drill holes for 10g screws to attach strike plate.

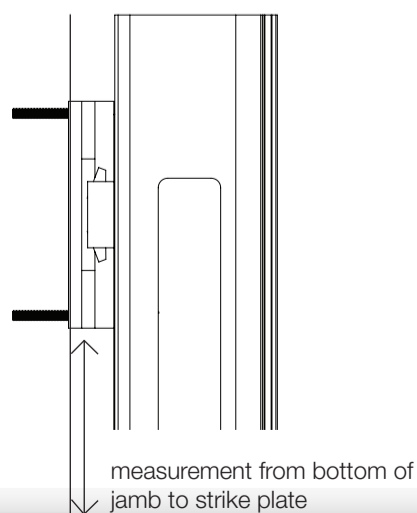

1. Cut out hole for lock in the centre of the stile. (only if stile is symmetrical.)

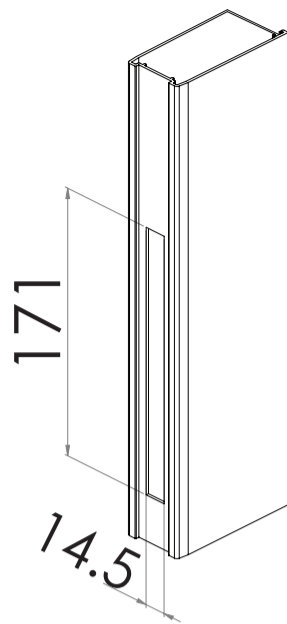

4. Drill holes for 10g screws to attach sliding lock into place.

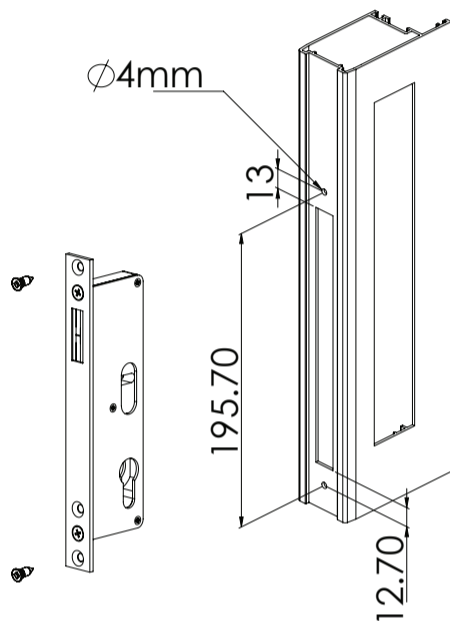

7. Insert Second handle Into frame, following steps 6 and 7 with the driving pin connecting into the Handle.

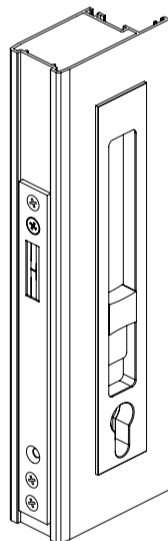

10. Check lock engagement and use adjustment with screws if necessary.

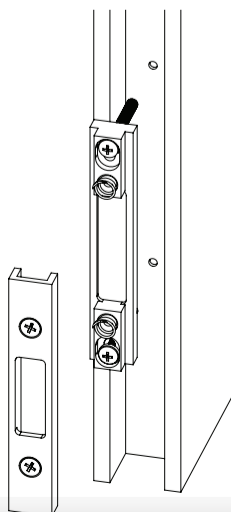

2. Cut holes out for handles on either face of the door, this will be 14mm (critical) above the bottom of lock cut out, and 13.25mm from the door edge (A).

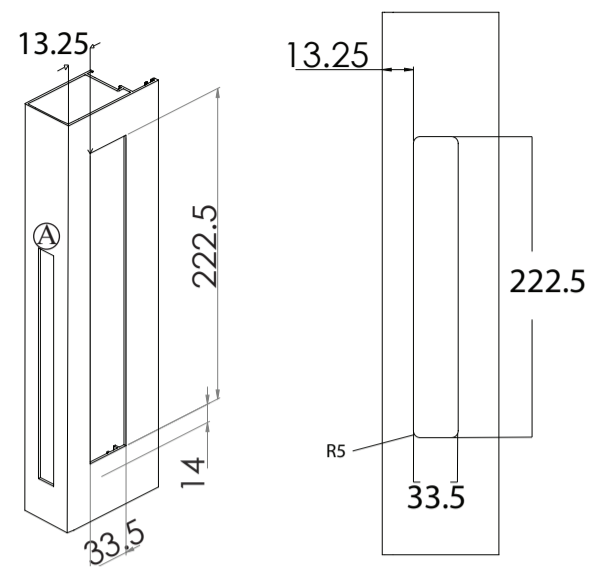

5. Insert rear handle as shown, insert pin (& button on single handles) through lock driving block and through to the handle which opens and closes the lock.

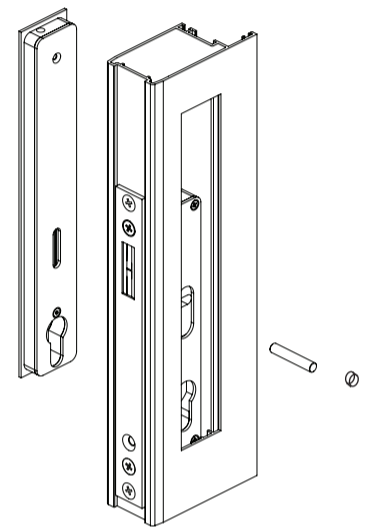

8. Push the euro cylinder lock through lock assembly, Tighten screw to lock cylinder in place.

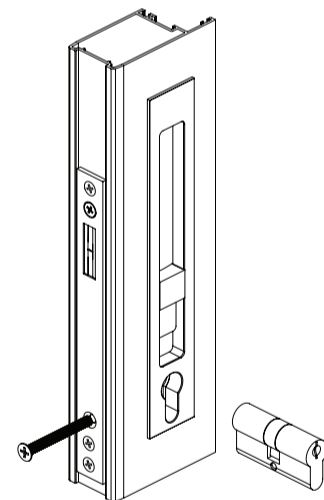

11. Place Strike plate cover onto base and adjust with screws for close fit.

